



User Manual

Energy Storage Inverter

Model: KY-1Hybrid-5k0-H



V1.0

1. Introduction.....	4
1.1. Introduction	4
1.2. How to Use the Manual	4
1.3. Applicable (warnings, precautions, notices)	5
1.4. Important Safety Information	6
1.5. General Safety Regulations for Working on Electrical Equipment	7
1.6. System selection	8
2. Technical Description of Inverter	9
2.1. Mechanical Design	9
2.2. Electrical Design.....	9
2.3 Reducing and Limiting Output Power	10
3. Inverter Working Mode	11
3.1. Standby Mode	11
3.2. Check Mode.....	11
3.3. Normal Mode	11
3.4. Fault Mode	12
3.5. Programming Mode	12
3.6. Shut Down	12
4. Installation and Start-up	14
4.1. Preparation for Installation.....	14
4.2. Mounting.....	15
4.3. ELECTRICAL WIRING CONNECTION.....	17
5. Communication and Monitoring.....	22
5.1. Summery.....	22
5.2. Communication.....	22
5.3. Monitoring	22
6. Maintenance and Repair	23
6.1. Precautions during Maintenance.....	23
6.2 .Safety Requirements during Maintenance	23
6.3.Daily Maintenance	23
7.Technical data.....	24
7.1 . Technical Parameters And Certificates	24
8. Warranty commitment	25
9. Contact Information	26
Appendix I: Common Problems.....	26

Appendix II: Abbreviations of Terms27

1. Introduction

1.1. Introduction

KY HYBIRD series, also called hybrid or bidirectional solar inverters, apply to solar system with PV, batteries, loads and grid system for energy management. The electricity from PV panels is used to optimize residential electricity consumption, the excess electricity can be stored in the batteries. When the batteries are fully charged, homeowners can feed the excess electricity to the utility grid.

Battery will discharge to power loads when electricity generated by PV is insufficient to meet self-consumption needs. If the electricity stored in batteries power is not sufficient, grid will power the loads via the system.

KY HYBIRD series are inverters without transformer non-isolated between DC input and AC output, the adaptive PV model must have IEC61730 Grade A.

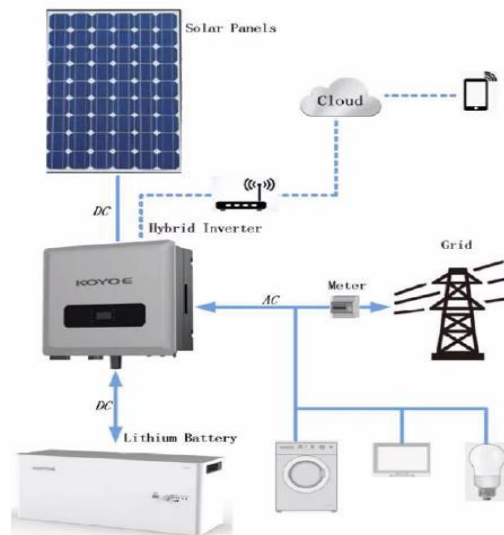

Note:

The introduction describes a general working mode of HYBIRD system.

The operation mode can be adjusted on KY INVAPP up to the system layout.

The general operation modes for KY HYBRID system are as below.

1.2. How to Use the Manual













Before using this inverter, please read the manual carefully. For this manual, it is assumed that the user is familiar with AC and DC systems and knows the rules and regulations regarding electrical equipment and its connection to grid of utility company. It is particularly important to be familiar with the general safety regulations related to the use of electrical equipment.

1.3. Applicable (warnings, precautions, notices)

Some of the important information shown below runs through different parts of this manual (where this important information is at this manual depends on the nature of the information):

The KY HYBIRD series inverters strictly comply with related safety rules for product design and testing. Please read and follow the instructions and cautions on the inverter during installation, operation or maintenance, as any inappropriate operation might cause personal or property damage.

SIGNS EXPLANATION

	Caution Failing to observe a warning indicated in this manual may result in injury.
	Danger of high voltage and electric shock!
	Danger of hot surface!
	Components of the product can be recycled.
	This side up! The package must always be transported, handled and stored in such a way that the arrows always point upwards.
	No more than six (6) identical packages being stacked on each other.
	Product should not be disposed as household waste.
	The package/product should be handled carefully and never be tipped over or slung.
	Refer to the operating instructions.
	Keep dry! The package/product must be protected from excessive humidity and must be stored under cover.
	Inverter will be touchable or operable after minimum 10 minutes of being turned off or totally disconnected, in case of any electrical shock or injury.
	CE Mark

Caution!

1. Must first connect the DC and AC earthing and then connect the DC input and AC output When disconnecting: last disconnect the earthing.
2. Need permission from the local utility prior to connecting the inverter to the utility grid and hire qualified personnel.
3. Observe all documentation that accompanies the inverter.
4. Installations maintenance and installed should be carried out by competent persons, who have sufficient skills and training to apply safe methods of work to install.
5. There is no maintainable part in the inverter. If there is any problem, it must be maintained by professionals.
6. All electrical installations must be done in accordance with the National Wiring Rules of Standard and local code 62109.
7. Non-isolated inverters : the PV modules should have an IEC61730 Class A rating.

8. The inverter is more 18kg, No handles and grips. Please be carefully to carrying and lifting. Equipment or parts having a mass of 18 kg or more shall be provided with a means for lifting and carrying or directions shall be given in the manufacturer's documentation.
9. The software version information can be read through the upper computer software .
10. The inverter is a non-isolated between DC input and AC output. The product marking must be readily visible after installation.
 - Risk of Electric Shock, Do Not Remove Cover. No User Serviceable Parts Inside. Refer Servicing To Qualified Service Personnel.
 - When the photovoltaic array is exposed to light, it supplies a dc voltage to this equipment.
 - Please not that DC input voltage must be less than 550V or the other . Too high voltage could cause damage to the inverter.
11. The N on the off grid side is not connected to the N on the grid side in the inverter. Please according to the requirements of local power grid.
12. Please avoid direct sunlight to the inverter.
13. When the inductive load of motor type is connected to the off grid port, please note that the instantaneous peak current of load starting shall not be greater than 40A.

1.4. Important Safety Information

Please read the manual before installation, operation and maintenance.



Permission from the local utility is required before connecting the inverter to the grid and employing qualified personnel.

Before installation:

Check the installation position to avoid direct exposure of the product to sunlight.

Check the inverter and package for damage. If in doubt, please contact the supplier before installing the inverter.

Before connecting PV panels to the inverter, please check the voltage of the inverter and ensure it is within the specifications of TRM inverter.

Observe all documentation that accompanies the inverter

The inverter is more 18kg, No handles and grips. Please be carefully to carrying and lifting

Installation:

All electrical installation must be carried out in accordance with national standard wiring rules and local specifications. Only the personnel who has been trained, authorized and familiar with local electrical regulations can install inverter. To ensure safety, follow the steps described in this manual. Please note that the inverter has two live terminals, PV input and grid.

The earth line must be connected before connecting the DC input and AC output. The product identification must be clearly visible after installation.



Disconnect the inverter:

Always disconnect the AC circuit first, then the PV circuit, and finally the ground wire. Please note that even if the inverter has been disconnected form the grid/main power supply and solar module, its voltage may still be very high and still dangerous at this time. After disconnecting from the grid and PV panels, please wait at least 20 minutes.





Operation/Maintenance:

Maintenance and installation of equipment should be carried out by qualified personnel with adequate skills and training who use safe working practices.

Before connecting the inverter to the grid, make sure that the mounting cover is refitted. Do not open it while the inverter is working. Risk of electric shock.

When the PV array is exposed to sun, it will supply DC voltage to this device.

There are no repairable parts inside the inverter, if there is any problem you must contact a professional for maintenance.

Performance safety parameters:

Unauthorized modification of performance safety parameters may cause injury or accident to personal or the inverter. In addition, this will result in the invalidation of all inverter operation certification

If non original spare parts are used, there will be no guarantee of CE compliance in terms of electrical safety, EMC and equipment safety.



Attention:

Before connecting PV, please confirm that the open circuit voltage of PV panel must be less than 550V, and the maximum power of PV input is 5500W.



Attention:

In off-grid mode, the EPS port output of the inverter is floating



Attention:

The inverter has integrated RCD detection module, will exclude possibility of DC residual current to 10mA, thus in the system an external RCD (type A) can be used(≥30mA).

1.5. General Safety Regulations for Working on Electrical Equipment

All personnel responsible for inverter installation, maintenance and service shall be trained and familiar with the general safety regulations to be observed when working on electrical equipment.

Personnel responsible for equipment installation and service must also be familiar with local requirements, rules and regulations and safety requirements.

To provide general guidance on safety, here are five well-known and widely accepted provisions. These provisions should in no way be regarded as exhaustive.



Personnel working on electrical equipment shall be responsible for personnel and property safety!

Cut off

Before starting any work, disconnect all cables that supply power to the workplace. Note that no voltage does not mean that the cable is disconnected.

Prevent reconnection

Prevent the system from being reconnected by labeling or closing / blocking the work area. If it is accidentally reconnected, it may cause serious accidents.

Check that there is no voltage in the system

With the voltage tester, make sure there is no voltage in the system. Check all terminals to ensure that there is no voltage on each conductor of the system.

Cover neighboring live components and prevent others from approaching

Cover all live system components that may cause injury during operation. Make sure the danger area is clearly marked.

1.6. System selection



Maximum PV voltage

When selecting the specifications of photovoltaic system, it must be ensured that the open circuit voltage of PV string will not exceed the maximum input voltage 550VDC of the inverter. The maximum open circuit voltage of PV series during parallel or series operation is 550 v. Voltage above this level may cause permanent damage to the inverter.

Maximum current of each DC terminal

The maximum current of each PV input terminal of this inverter is 12A, which may cause permanent damage to the inverter.

The selection output of PV string should be based on the principle that investment capital can be used optimally, rather than on the expected energy output of the system each year. This optimization depends on local climate conditions and should be considered in all cases.

The inverter is equipped with input and output power limiting devices, which can automatically maintain the power at a safe level for the inverter. The limit range mainly depends on the internal and ambient temperature. The system constantly calculates the limits, which always allows the system to produce as much energy as possible.

Please use the tools provided by KOYOE to calculate the configuration of PV system.

2. Technical Description of Inverter

2.1. Mechanical Design

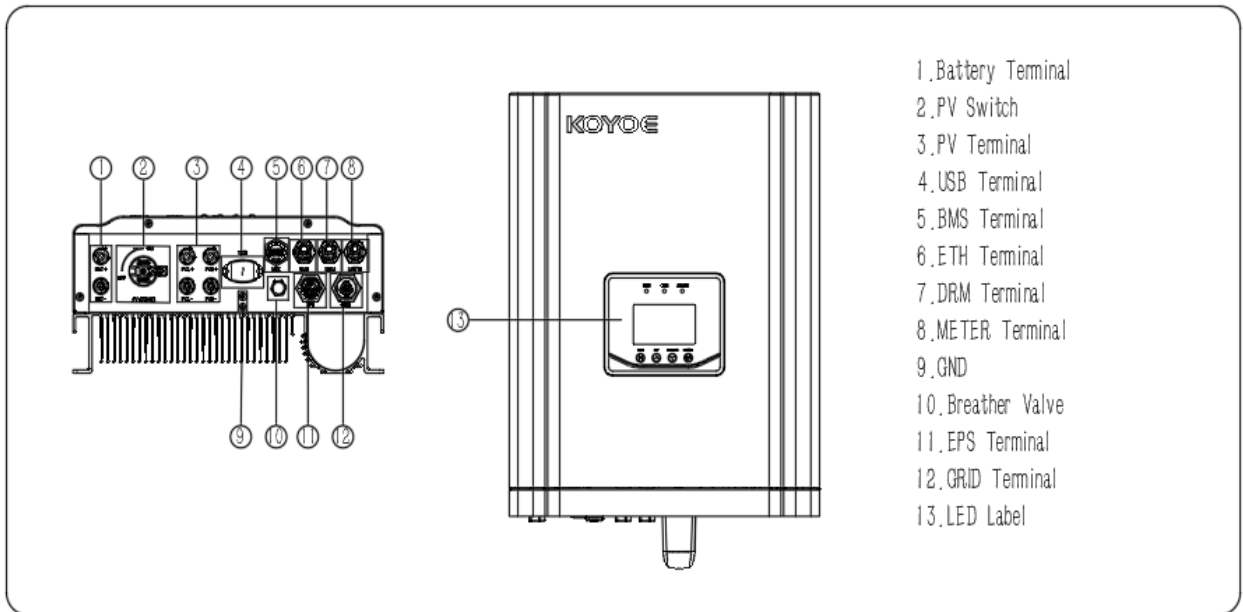

Be careful!

The input DC switch is located on the left side of the inverter. When moving the inverter, pay attention to keep a distance to avoid damage.



Be careful!

For safety reasons, it is recommended to use DC switch between PV arrays and power modules (this measure is mandatory in some countries).

2.2. Electrical Design

The power of PV string is transmitted to the DC bus of inverter through boost circuit, and the inverter circuit converts DC into AC and feeds it into power grid.

Two DC inputs of TRM inverter are equipped with MPPT to ensure maximum output power even under different PV input voltage conditions.

The KY HYBIRD series inverters have two PV input functions, and include grid-connected, energy storage and other functions in one inverter, the system diagram is shown in following figure:

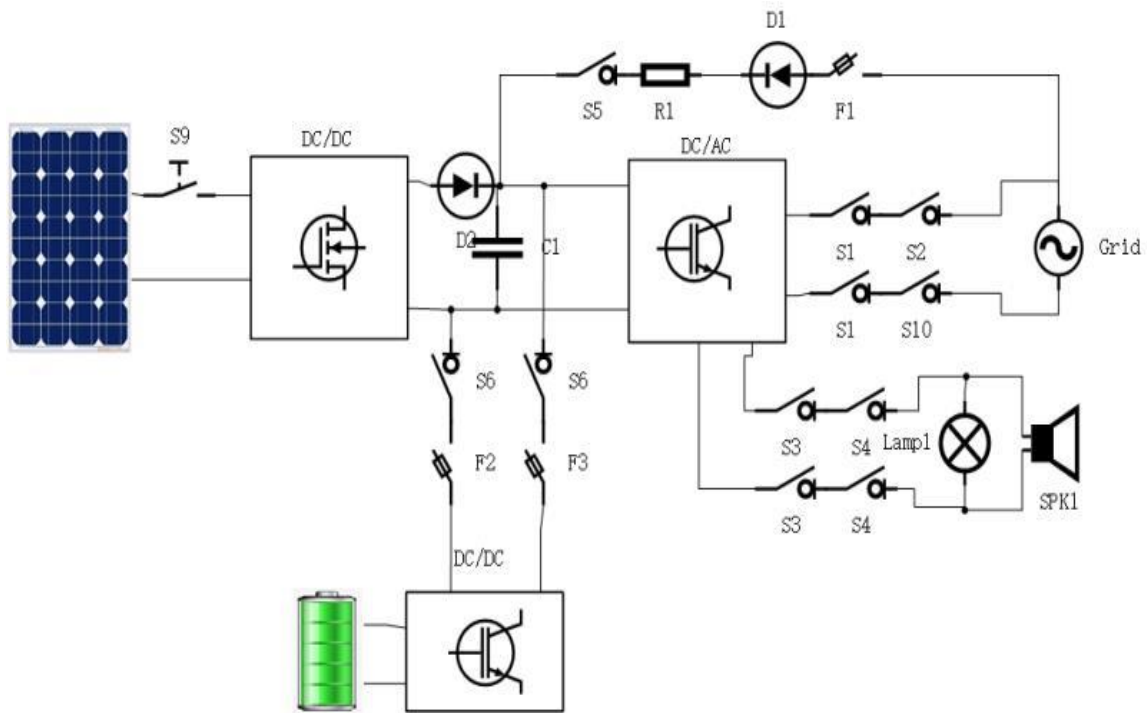

2.3 Reducing and Limiting Output Power

The operation of inverter derating is a method to avoid overload or restrain potential fault. In addition, the derating function can be activated under specific grid conditions according to the requirements of grid company. The inverters have the following derating conditions:

- When the ambient temperature exceeds 73 °C or the temperature of power device exceeds 85 °C, stop outputting power.
- When the ambient temperature is between 60-73 °C or the temperature of power device is between 81-85 °C, the output power is reduced linearly.
- External power level adjustment.

	<p>Only authorized personnel can make external power level adjustments</p>

The inverter supports a variety of power quality response modes, detailed as follows:

1. Volt response mode

1.1) Volt-watt response mode:

Open by default from the factory. The response curve range is set according to the default value. If necessary, the range can be modified by the upper computer.

1.2) Volt-var response mode:

Close by default from the factory. The response curve range is set according to the default value, if necessary, the range can be modified by the upper computer.

1.3) Voltage balance modes:

This inverter does not have this function.

2. Fixed power factor or reactive power mode:

Close by default from the factory. It can be modified by the upper computer.

3. Power response mode ($\cos \phi$ (P)):

Close by default from the factory. It can be modified by the upper computer.

4. Power rate limit:

Close by default from the factory. It can be modified by the upper computer.

3. Inverter Working Mode

The photovoltaic grid connected inverter can be divided into five working modes in the whole working process: standby mode, check mode, normal mode, fault mode and programming mode.

3.1. Standby Mode

When the inverter is only connect to the PV, BAT, or the Grid. The inverter will enter the check mode.

3.2. Check Mode

When the inverter is powered on, it will automatically detect the insulation, current sensor, leakage protector, relay and other components according to the sequence, and soft start. In this way, the inverter can work normally and enter the normal operation mode smoothly.

3.3. Normal Mode

KY HYBIRD system normally has the following operation modes based on your configuration and layout.

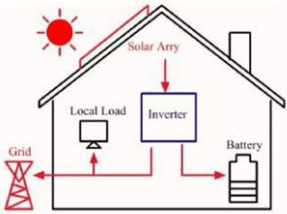
	<p>Mode: PV-Bat-Grid-Mode (with PV) Priority : load>battery>grid</p>	<p>The power generated from PV will be used to supply home loads firstly, then to charge the battery. The superfluous power will feed the public grid. When user connected the smart meter to the grid, you can set the power value feeding to the grid.</p>
---	--	--

	<p>Mode: Bat-Grid-Mode (without PV)</p>	<p>When no PV supplied, battery will discharge for home loads firstly, and grid will supply power when the battery capacity is not enough. Users can set the battery charging and discharging time according to the peak valley electricity price of the grid.</p>
	<p>Mode: EPS-Mode</p>	<p>When the grid is off, PV or battery can be the emergency power supply to power up the home loads (Battery is necessary in EPS mode)</p>

3.4. Fault Mode

When there is a fault in the operation, the inverter will stop the output power and enter the fault mode, and the fault information will be displayed on the LCD. Before entering the fault mode, the inverter will automatically store the output power into EEPROM. The general fault will be automatically removed within 5 seconds, and the inverter will resume operation. When a serious fault occurs, the inverter will stop in the failure mode until the relevant technical personnel remove the fault.

3.5. Programming Mode

No matter what working mode the inverter is in, when the system needs programming, the inverter will enter the programming mode and rewrite the firmware in DSP flash memory.

3.6. Shut Down

When the grid voltage, battery voltage and PV voltage is lower than setting value, the inverter will shut down. If there is no fault and the light intensity increases gradually, the inverter will start smoothly the next day.

3.7. Safety Setting

Users can set the working mode of the inverter through LCD. In general, the factory setting is the default parameter of the corresponding country.

Users can set safety rules according to the actual environment they are using. The operation of setting safety rules is shown in the figure below:

Step 1: Press the "Enter" button in the main interface to ENTER the interface below, select the "Settings" option through the "Up" button and the "Down" button, and then press the "Enter" button to ENTER the next level menu.

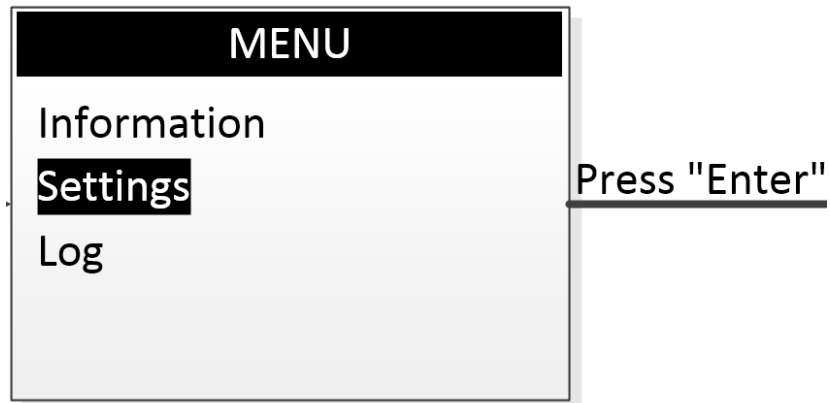

Step 2: After entering the following menu, select the option of "Safety Setting" through the "Up" and "Down" buttons, and then press the "Enter" button to Enter the next menu.

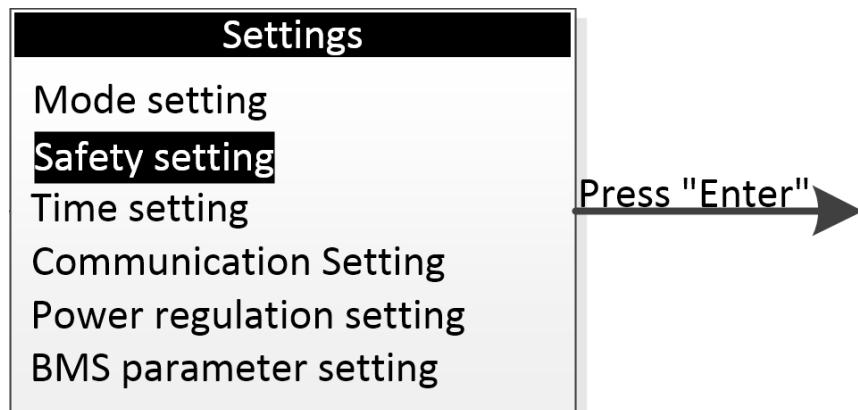

Step 3: After entering the following menu, enter the password through the "Up" button and "Down" button to enter the next menu. Safety information is an important parameter, in order to ensure the safety of users and set, password can be obtained by consulting customer service.

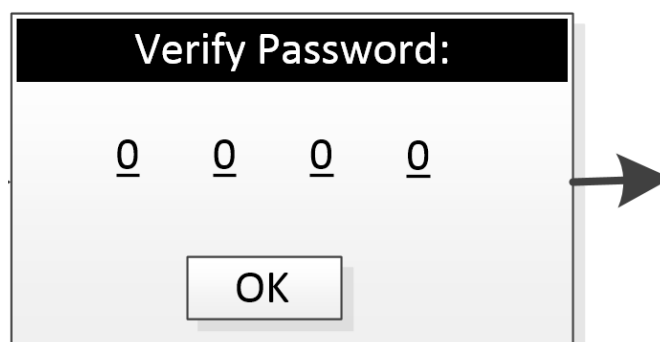

Step 4: After the password is entered correctly, the user can Enter the following menu. The user can select the safety rules that need to be set through the "up" and "down" keys, and then press the "ENTER" button to confirm. After successful setting, "OK" will be prompted, and then press the "Esc" key to return to the main screen.



4. Installation and Start-up

4.1. Preparation for Installation



Warning!

Before installation and maintenance, both AC and DC terminals are dead. However, if the DC input has just been cut off, the capacitor inside the device will still store electricity. So please wait for at least 20 minutes to ensure that the capacitor will release the electricity and the equipment is not electrified.



Be careful!

The inverter must be installed by professionals.
Don't expose the product to direct sunlight.

Our company will provide warranty service for your purchased PV grid connected inverter within 5 years after purchase. If you do not install the inverter according to the requirements of this manual, the warranty will become invalid. The content of warranty is limited to the cost of product repair or replacement.

Ventilation is very important for heat cooling of inverter. Under outdoor conditions, the inverter needs operating room at least 200 mm left and right and at least 300 mm up and down.

Note:

EPS-PORT CAN NOT CONNECT IN PARALLEL;

- 1) SINGLE PV STRING CAN NOT CONNECT TO TWO OR MORE INVERTERS;
- 2) ONE SMART METER CAN NOT CONNECT TO MULTI INVERTERS, AND DIFFERENT CT CAN NOT CONNECT TO A SAME FIER CABLE;
- 3) ONE BATTERY PACK CAN NOT CONNECT TO MULTI INVERTERS;
- 4) EPS-PORT CAN NOT CONNECT TO GRID.

4.1.1. Packing List

On receiving the inverter, please check to make sure all the components as below are not missing or broken.



4.2. Mounting

4.2.1. Select Mounting Location

For inverter's protection and convenient maintenance, mounting location for inverters should be selected carefully based on the following rules:

Rule 1. Inverter should be installed on a solid surface, where is fit for inverter's dimensions and weight.

Rule 2. Inverter installation should stand vertically or lie on a slop by max 15° (see following picture)

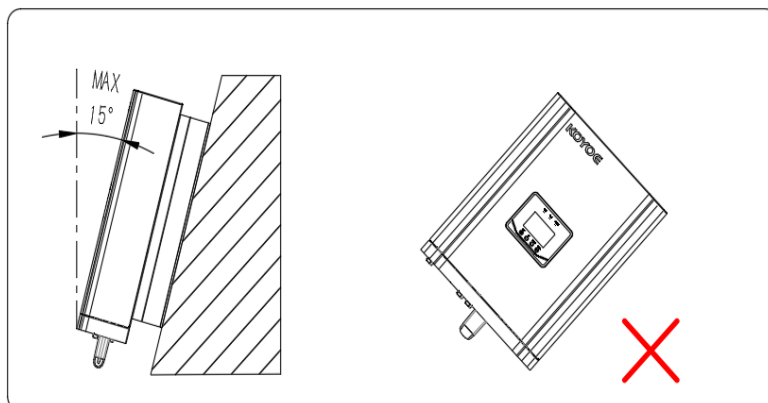

Rule 3. The installation of inverter should be protected under shelter from direct sunlight or bad weather like snow, rain, lightning etc. (Pic 2)

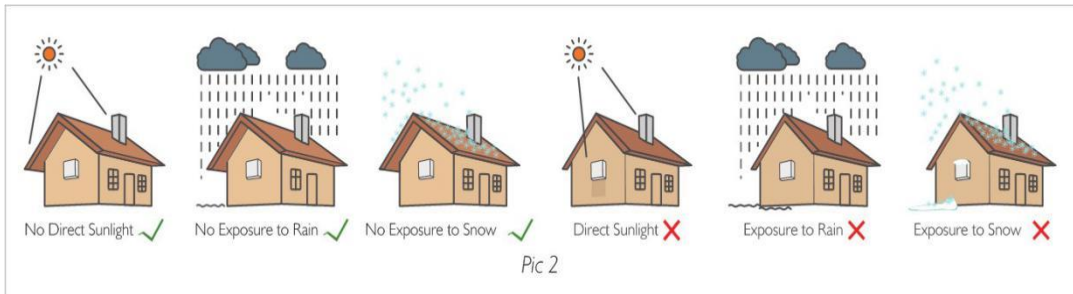

Rule 4. Inverter should be installed at eye level for convenient maintenance.

Rule 5. Product label on inverter should be clearly visible after installation. Rule 7. Leave enough space around inverter following the values on the following picture..

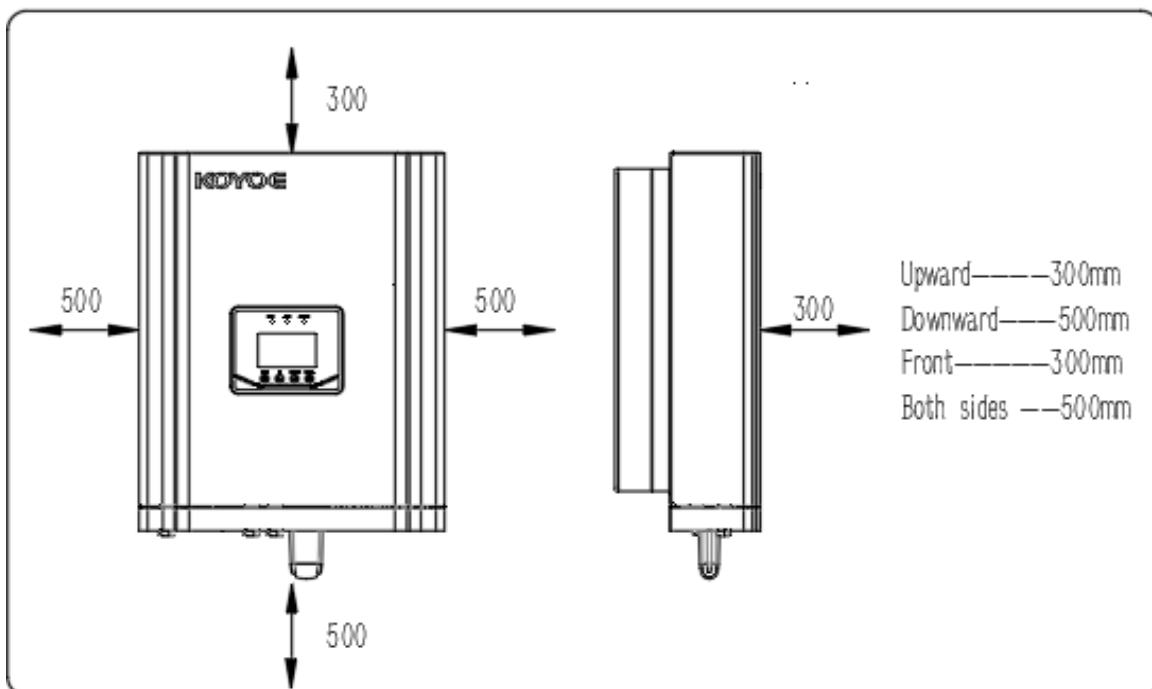

Be careful!



Our company will provide warranty service for your purchased PV grid connected inverter within 5 years after purchase. If you do not install the inverter according to the requirements of this manual, the warranty will become invalid. The content of warranty is limited to the cost of product repair or replacement.

Ventilation is very important for heat cooling of inverter. Under outdoor conditions, the inverter needs operating room at least 500 mm left and right and at least 500 mm up and down.

4.2.2. Mounting the inverter

Remember that this inverter is heavy! Please be careful when lifting out from the package. The inverter is suitable for mounting on concrete or other non-combustible surface only.

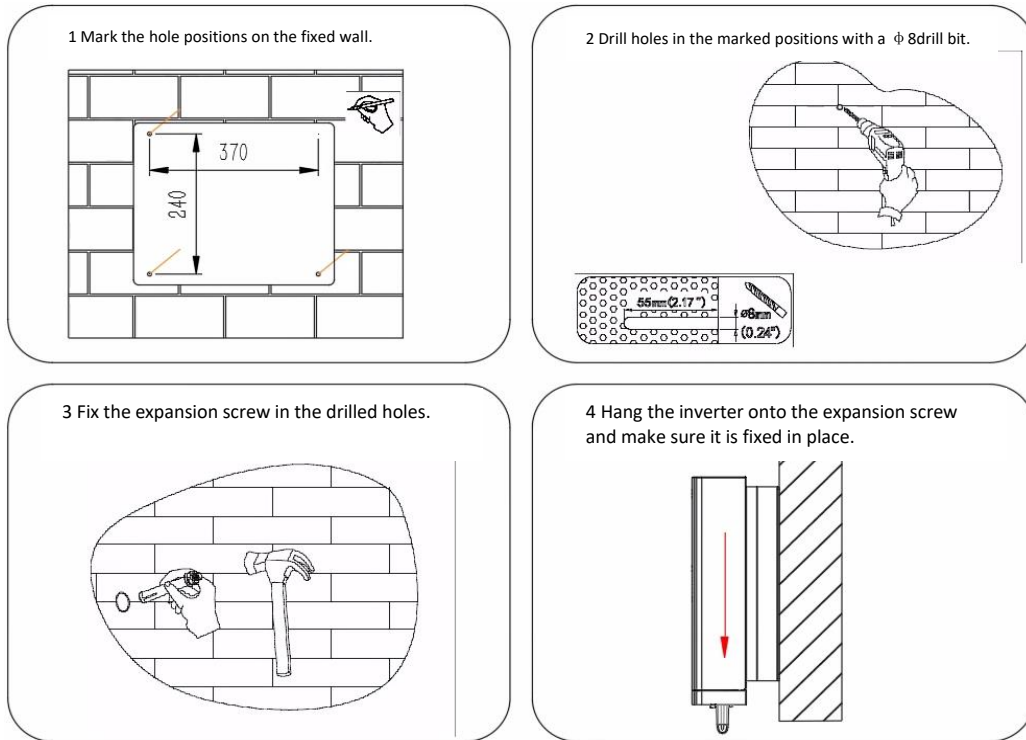

Step1: Mark the hole positions on the fixed wall;

Step2: Drill holes in the marked positions with a $\phi 8$ drill bit.

Step3: Fix the expansion screw in the drilled holes.

Step4: Hang the inverter onto the expansion screw and make sure it is fixed in place.

4.3. ELECTRICAL WIRING CONNECTION

4.3.1. PV CONNECTION

Before connecting PV panels/strings to inverter, please make sure to meet the requirements as below:

The minimum isolation resistance to ground of the PV string must exceed 18.33k Ω in case of any shock hazard;

PV strings could not connect to earth/grounding conductor;

Use the DC plugs in the accessory box.

NOTE: There will be MC4 or Amphenol DC plugs in accessory box, the detailed connection as below:

Step1: Prepare PV cables and DC plugs

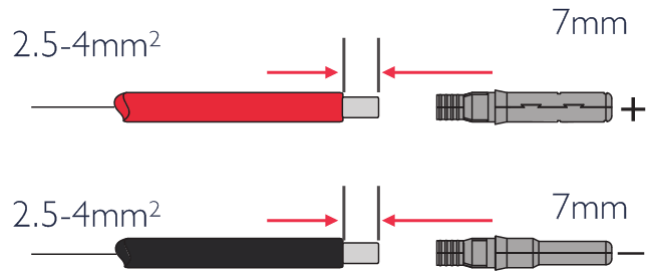

Be careful!

- Please use DC plugs and connectors in KOYOE accessory box
- PV cable should be standard, 2.5-4mm² PV cable

Step2: Connect PV cable to DC connectors

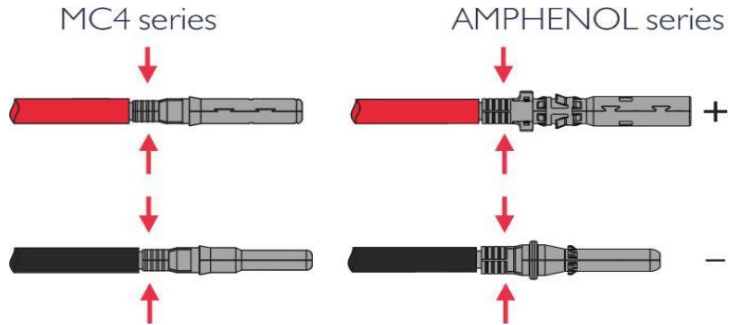

Be careful!

- PV cable must be tightly crimped into the connectors;
- For Amphenol connector, the limit buckle cannot be pressed;
- There will be a click sound if connectors are inset correctly into DC plugs.

Step3: Screw the cap on and plug onto inverter side

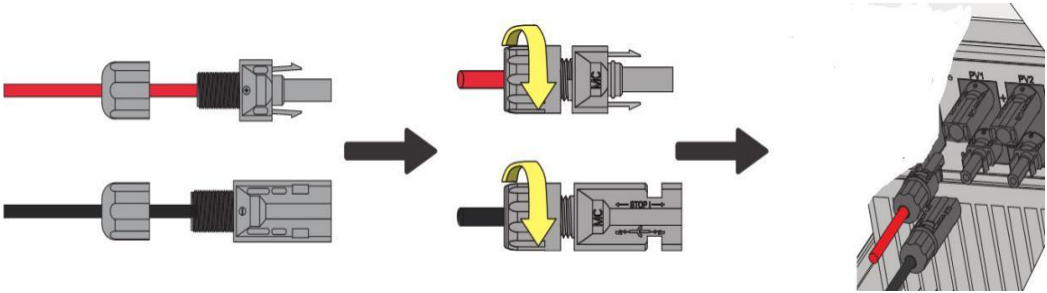

4.3.2. Battery CONNECTION

This inverter support many types of batteries, such as lead-acid, ni-mh, lithium iron phosphate, lithium manganite, cobalt acid lithium, polymer lithium battery ternary material. Please pay attention to the input range of battery voltage when using the battery.

The battery side interface can be installed according to the above method. If you have any questions, please consult the customer service personnel.



Be careful!

This inverter does not have the function of remote battery temperature detection. When using lead-acid batteries, please confirm with the battery manufacturer the safe operating environment and conditions.

When using lithium battery, must connect the lithium battery communication line, the inverter can work normally. The inverter uses CAN communication to connect with the battery's BMS. The interface definition of the inverter is shown in the figure below. Please match according to the battery's instruction manual.

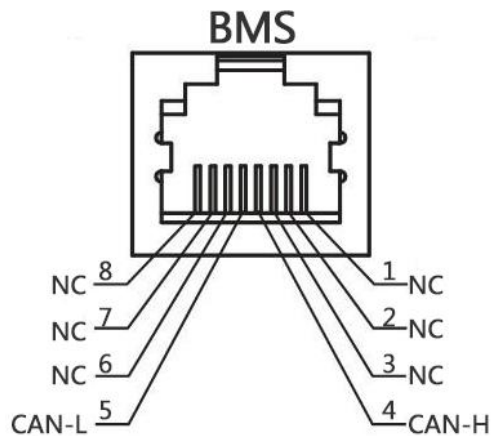

4.3.3. ON-GRID&OFF-GRID CONNECTION

An external AC switch ($\geq 40A$) is needed for on-grid connection to isolate from grid when necessary.

Please conduct wiring according to the identification on the interface, 6mm² cable is recommended for connection.

Step1: For the safe operation of system, the recommended wire specifications are shown in the figure.

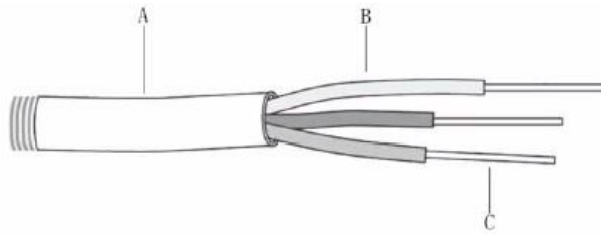

Label	Description	Data
A	Wire Outer Diameter	11-12mm
B	Wire Cross-sectional Area	6mm ²
C	Bare Wire Length	10mm

Step2: Prepare supporting AC terminals with L and N and PE (the first

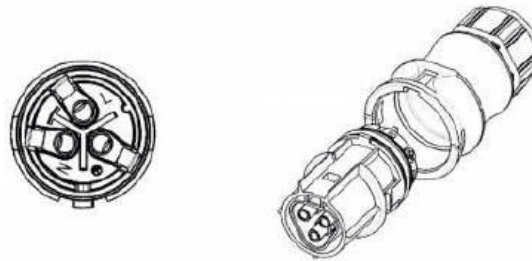

Step3: Make sure that the city power is disconnected and connected to the L, N and ground terminals of the city power and fixed with screwdriver.

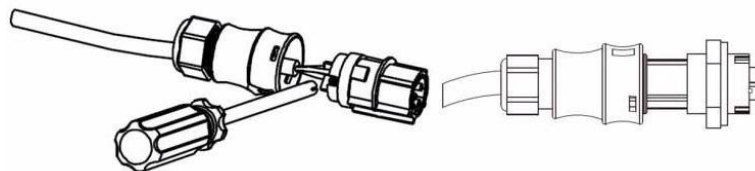

Step4:Ground cable shall be connected to ground plate on external enclosure.

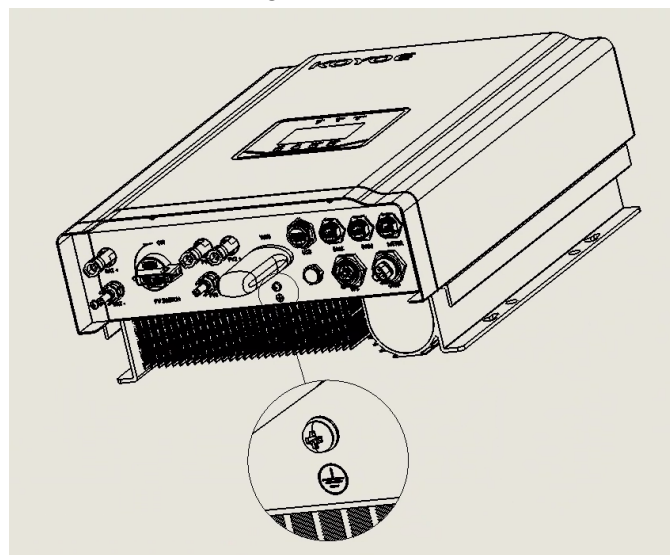

Step5: Refer to the wiring diagram below.

The Hybrid inverter is floating output when at stand alone mode. Should be ensure that the continuity of the neutral conductor to the load from the electrical installation is not interrupted when the inverter disconnects from the grid and supplies a load via the stand-alone port. Should be comply with AS/NZS 3000 and AS/NZS 4777.1. and refer below circuit diagram.

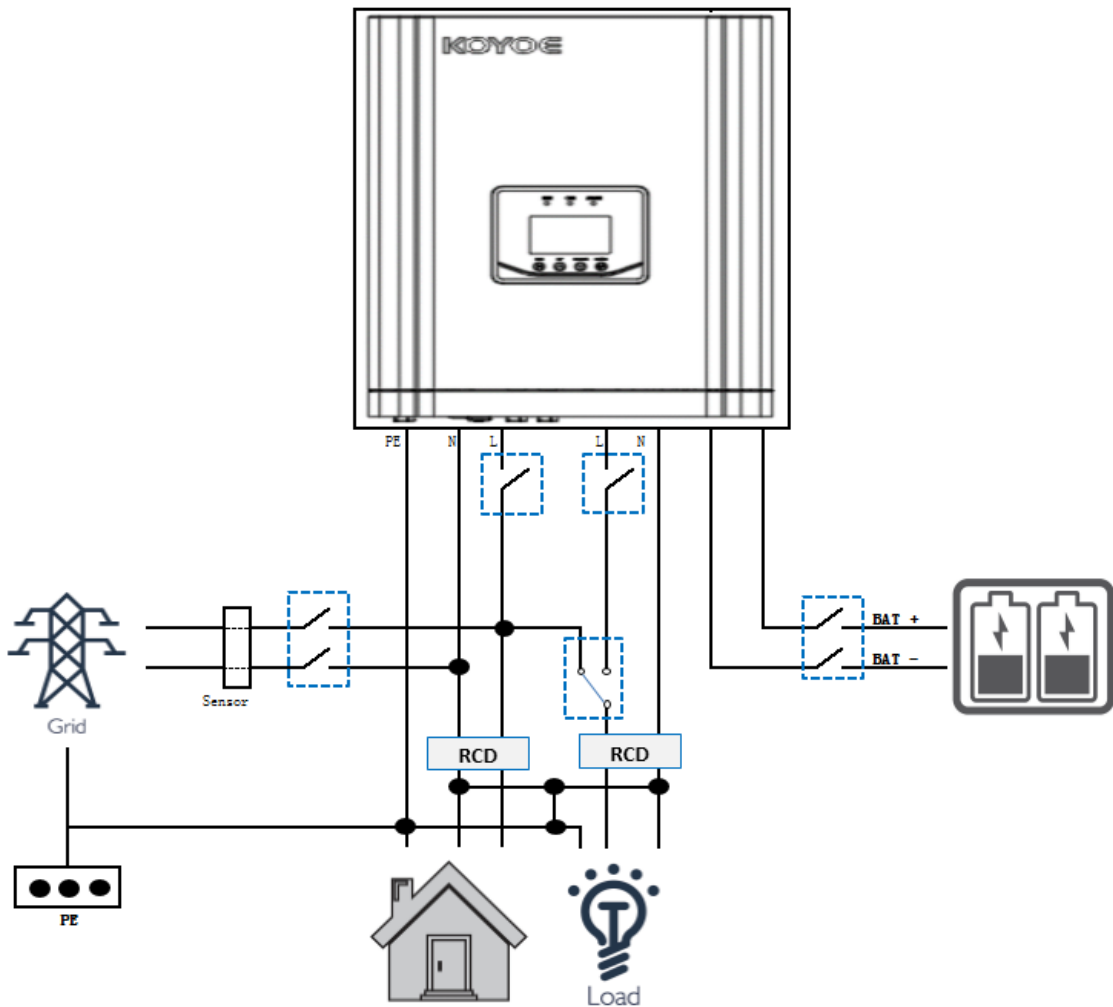

4.4. Commissioning

Before starting the equipment, please confirm that:

- The PV cable, Battery cable and AC cable and EPS cable is correctly connected to the AC side terminal of inverter through AC circuit breaker;
- The DC cable is correctly connected to the DC side terminal of the inverter through the DC circuit breaker. Please note: the cable is correctly connected to the two branches and the correct polarity connection is ensured;
- Unused terminals shall be sealed with end caps.

Power on:

Step 1: close DC and AC circuit breakers;

Step 2: if the PV panel can provide enough power, the power module will work and light up the LCD panel;

Step 3: the inverter will enter the self-check mode, and the LCD will display the remaining

reconnection time;

Step 4: when the inverter enters the normal mode, the power will be fed into the grid, and the LCD will display the power generation.

5. Communication and Monitoring

5.1. Summary

KY3GT-20K/KY3GT-17K/KY3GT-15K/KY3GT-12K/KY3GT-10K inverter provides RS-485, WIFI, GPRS and other communication interfaces, and is equipped with a monitoring system, which can remotely browse the output voltage, current, grid frequency, fault and other information. At the same time, these parameters are stored in the local PC to facilitate the query of historical records.

5.2. Communication

Users can browse the data of the inverter remotely through the communication interface, and the inverter provides two kinds of communication interfaces.

5.2.1. RS-485 Communication

RS-485 is usually used for local monitoring or connecting to the third-party data collector: when connecting to the local monitoring, the RS-485 interface of the inverter can be connected to the USB interface of the computer through the USB to RS-485 converter, and the maximum length of the RS-485 cable should not exceed 1200m. Users can view and record the current power generation, working status and error information of the photovoltaic power station through the PVCs software installed on the computer.

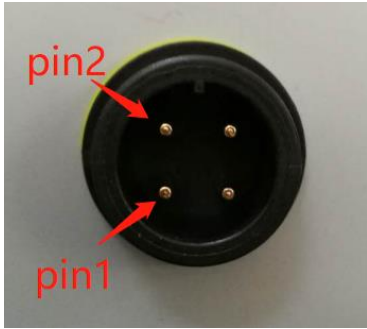
PIN1	VCC	
PIN2	GND	
PIN3	RS-485_A	
PIN4	RS-485_B	



Be careful:

1. The wiring sequence of 2 terminals of 1 RS-485 cable shall be consistent.
2. If the customer needs RS-485 to communicate with inverter, they need to purchase USB to RS-485 converter.

5.2.3. WiFi / GPRS Communication

KY HYBIRD series inverter can be configured with a WiFi / GPRS communication module to realize communication networking.

5.3. Monitoring

1. Local monitoring system

The local monitoring software is connected to the inverter through USB to RS-485

converter.

2. Remote monitoring system

When the WiFi/GPRS communication module is inserted into the inverter, the customer can monitor the inverter information through the monitoring website of KOYOE. The user opens the web browser and enters the web address: <http://www.koyoe.com/>. After registering an account, enter the user name and password to log in, and the user can monitor the voltage, current and power of the inverter.

In apple and android app stores, enter the KOYOE-log keyword, and users can download apps to your mobile device. After installation, enter your user name and password, you can access your power station to view the inverter information.

Note: for details of WiFi/GPRS communication module, please refer to the corresponding communication module manual.

3. Read the software version number

You can read the software version number on LCD or Internet or mobile with WIFI/GPRS.

6. Maintenance and Repair

6.1. Precautions during Maintenance

When the inverter fails, the inverter will automatically disconnect from the grid and send fault or warning information. For solutions to simple faults, please refer to the common in Appendix I.

6.2 .Safety Requirements during Maintenance



For the operation running and after operation, the shell temperature is high due to the heat generated by power circuit, which is at risk of scalding. Contact operation shall be carried out after cooling.



Before removing the fault, it is necessary to ensure that the circuit breaker of DC or AC circuit is disconnected, and professional personnel are contacted to deal with it. Other people are not allowed to close the circuit breaker without authorization.



There is no repairable part in the inverter. If there is any problem, it must be maintained by professionals. Even if the inverter has been disconnected from PV and battery and power grid, it may still have dangerous voltage. Before starting work related to electronic system in the cabinet, the voltage of DC bus should be measured first. This voltage must be below 48V.

6.3.Daily Maintenance

Usually, the inverter does not need regular maintenance and calibration. Due to natural heat dissipation, the radiator must not be covered by dust and other dirt.

In order to ensure good ventilation of the inverter, it is necessary to check the radiator and make sure that it is unobstructed.

If necessary, clean the inlet and outlet of the inverter with a soft brush. Do not use water,

corrosive chemicals or strong detergents to clean the inverter.

7. Technical data

7.1 . Technical Parameters And Certificates

Specifications	
Model	KY-1Hybrid-5k0-H
PV input	
Vmax PV	550V d.c.
Isc PV (absolute Max.)	15A/15A
Max PV input power	5500W
Number of MPP trackers	2
Number of input strings	1/1
Max. PV input current / string	12A/12A
MPPT voltage range	120-500Vdc
Vdc range @ full power	250-500Vdc
Nominal PV Input Voltage	380V
Max Inverter Backfeed Current to Array	0A
Battery (input and output)	
Max Input/Output Voltage	450V
Nominal Battery Voltage	300V
Operating Voltage Range	85V ~450V (self-adapt)
Max charge/discharge Current	25A/25A
Max Input/Output Power	5000W/5000W
Battery Type	Li-ion(LFP)
AC Grid (input and output)	
Normal Voltage	230VAC, 1 ϕ (L/N/PE)
Frequency	50Hz
Max. continuous input/output current	21.7A
Max Output Fault Current	22.7A
Max Output Over Current Protection	23.7A
Inrush Current(peak and duration)	88.5A peak@25.2us
Max. continuous output Power	5000W
Max. continuous output Power	5000VA
Power factor and PF range	>0.99 (-0.8~+0.8)
Off-Grid AC Output (Backup AC output)	Maybe work at stand-alone mode
Normal Voltage	230VAC, 1 ϕ (L/N/PE) (N not connect PE inside)
Frequency	50Hz
Nominal Output Current	21.7A
Nominal Output Power	5000W
Nominal Output Power	5000VA
others	

Protective class	Class I
Ingress protection	IP 65
Working temperature	-25°C to 60°C (derating 45°C)
Overvoltage category	OVC II(PV) , OVCIII(AC main Grid)
Humidity	4% ~ 100 %
Isolation	Transformerless
Condition	Outdoor unconditioned
Dimensions	390*500*185mm
Weight	18kg

Safety and Protection	YES/ON
Over/under voltage protection	YES
DC isolation protection	YES
Monitoring ground fault protection	YES
Grid protection	YES
DC injection monitoring	YES
Back feed current monitoring	YES
Residual current detection	YES
Anti-islanding protection	YES(Frequency shift)
Over load protection	YES
Over heat protection	YES

8. Warranty commitment

In order to provide you with high-quality service and better protect your rights and interests, please read this regulation carefully and keep your quality assurance card and purchase invoice.

We will provide you with standard warranty service for 60 months. From the date of purchase, during the warranty period, we will provide you with free warranty and maintenance services. The faulty inverter needs to be returned to the factory for repair, so please keep the original package properly. If the customer uses the new packing box, the packing cost and transportation cost will be borne by the customer. During the warranty period, the customer needs to provide the original invoice and quality card, and the label of the inverter body is clearly visible. If these requirements cannot be met, we will not be able to provide you with perfect service.

This regulation is applicable to TRM series photovoltaic grid connected inverter produced by KOYOE. All products purchased through regular channels shall enjoy the full range of quality assurance services provided by the company, except for the following situations:

1. Beyond the warranty period;
2. No valid quality assurance card and product serial number;
3. Transportation damage;
4. Improper use, operation and modification;
5. Operating in an environment beyond the specified in this manual;
6. Any installation and use beyond the scope specified in relevant international standards;
7. Damage caused by abnormal natural disasters (earthquake, fire, flood, etc.).

9. Contact Information

If you have any questions about the PV grid connected inverter or technical issues, please contact us:

Jiangsu KOYOE Energy Technology Co., LTD

Address: NO.40, Wangwu Road, Wuzhong District, Suzhou, China

Tel: +86 512 6513 9208

Email: koyoesales@szzcph.com, sales_Int@koyoe.com

Web: en.koyoe.com

Appendix I: Common Problems

In case the inverter will not work normally at times, solutions to common problems are listed below. This will help technicians understand problems and take effective measures.

	LCD display	Possible Causes and Solutions
Fault can be cleared	ISO fault	<ol style="list-style-type: none"> 1. Check whether the inverter is effectively earthed and whether the impedance between the positive and negative poles of the photovoltaic cell is greater than 1m Ω; 2. Check whether the AC side is connected to the earth.
	GFCI fault	<ol style="list-style-type: none"> 1. The grounding current is too high. 2. After disconnecting the AC side circuit, pull out the photovoltaic cell at the input end and detect the peripheral equipment of the AC system. 3. After removing the fault, re connect the PV panel and AC side circuit to detect the inverter status.
	Grid failure; Frequency overrun; AC voltage overrun;	<ol style="list-style-type: none"> 1. Wait for 5 minutes. If the power grid returns to normal, the inverter will restart automatically. 2. Ensure that the grid voltage and frequency meet the local specifications.
	High temperature	<ol style="list-style-type: none"> 1. The internal temperature of the inverter is higher than the normal value. 2. Keep the ambient temperature as low as possible. 3. Or put the inverter in a low temperature environment.
	PV overvoltage	<ol style="list-style-type: none"> 1. Check whether the DC open circuit voltage of photovoltaic cell is greater than 550v. 2. If the DC open circuit voltage of photovoltaic cell is less than 550v and the problem still exists, please contact the local after-sales service department.
	BAT voltage low	<ol style="list-style-type: none"> 1. Check whether the battery voltage is lower. 2. Check whether the communication is connected to the BMS.
Fault can't be cleared	Consistency failure	Disconnect the positive and negative poles of the photovoltaic cell from the input end of the inverter, and restart the inverter.
	Relay self-check failed	1. Disconnect the positive and negative electrodes of photovoltaic cells from the inverter.
	High DC current injection	<ol style="list-style-type: none"> 2. Wait for a while. 3. After the LCD is turned off, reconnect and retest.

	SCI failure	4. If the problem still exists, please contact the local after-sales service department.
	HCT failure	

In addition to the above common problems, if you encounter other unsolvable problems, please contact us, we will try our best to provide you with quality service.

Appendix II: Abbreviations of Terms

AC	Alternating Current
DC	Direct Current
DLU	Data recorder
DSP	Digital Signal Processor
EEPROM	Electrically Erasable Programmable Read Only Memory
EMC	Electromagnetic Compatibility
EMI	Electromagnetic Interference
GFCI	Grounding fault current leakage protector
HCT	Hall Current Transducer
HMI	Human Machine Interaction
LCD	Liquid Crystal Display
LED	Light Emitting Diode
MPPT	Maximum Power Point Tracking
PC	Personal Computer
PV	Photovoltaic
PVCS	Photovoltaic Control System
SCI	Serial Communication Interface